

PEPPERDINE UNIVERSITY

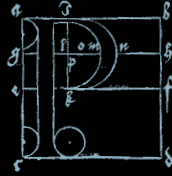

# STRATEGIC PLAN

PEPPERDINE 2020:  
BOUNDLESS HORIZONS

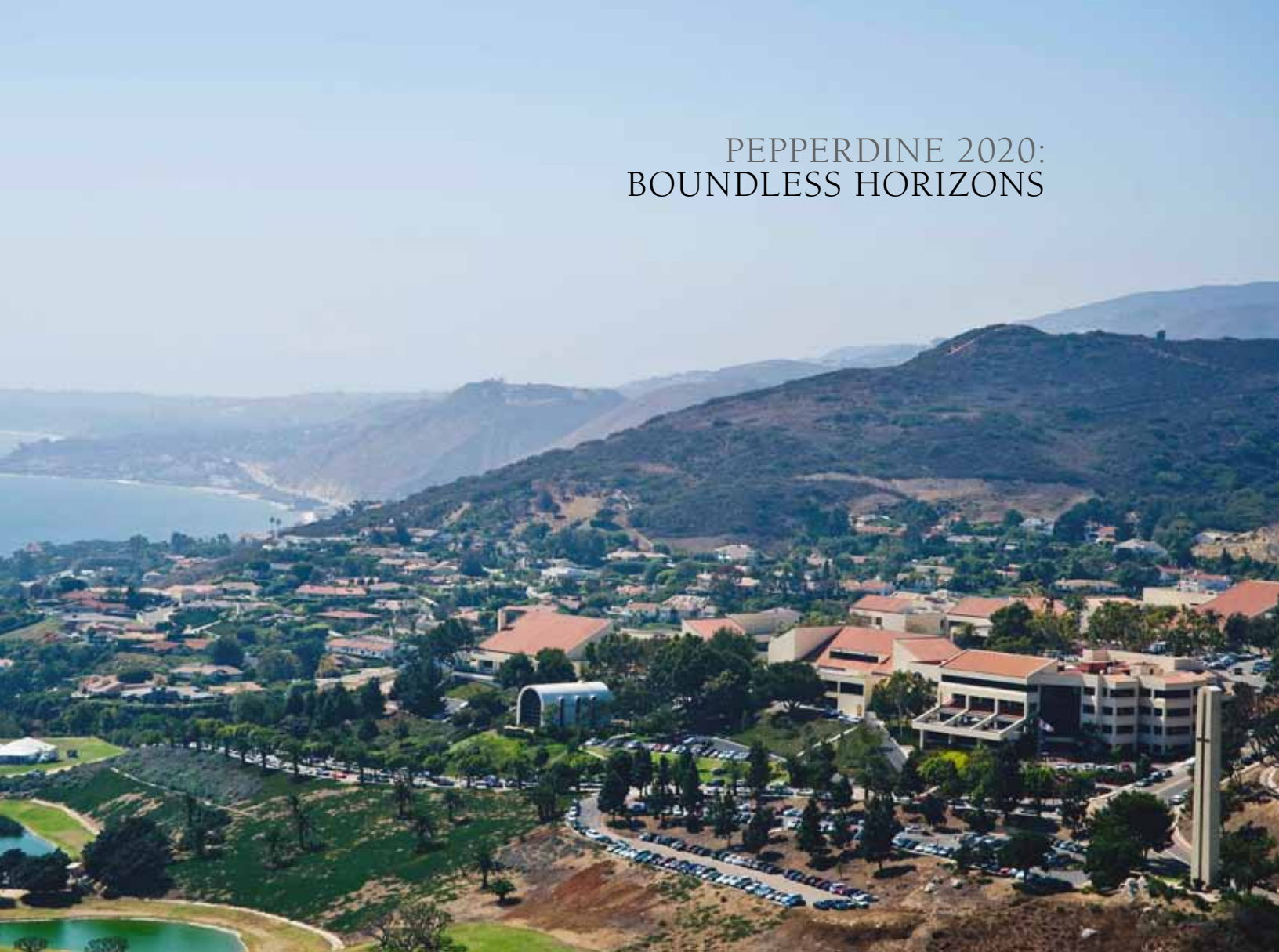

# STRATEGIC PLAN

## PEPPERDINE 2020: BOUNDLESS HORIZONS



*Adopted by the Board of Regents on June 14, 2011.*

## PREAMBLE

This Strategic Plan is the shared work of the Pepperdine community, the product of much discussion and conversation among multiple stakeholders and constituents of the University stretching over five years. The process began in 2006 when the University Planning Committee assessed performance, institutional resources, and external trends that would likely affect the University's health and future. Eight study groups comprising 58 faculty, staff, and administrators identified the key trends that could conceivably impinge upon the University over the next decade. The results were presented to the University Planning Committee and to audiences on three campuses in Malibu, Los Angeles, and Orange County. Vision gap analyses were conducted, as was a current-state assessment by school and major unit. In the fall of 2008 a first draft of the Strategic Plan was distributed to the community for feedback. Since that time, many groups and individuals, including faculty, staff, administrators, student leaders, members of boards of visitors, members of the Alumni Leadership Council, and the University Regents, have reviewed the document and offered many helpful suggestions. We offer our sincere thanks to the many friends of the University for creating a compelling vision for our University's future. May we be faithful to the dream of a greater Pepperdine University.

## INTRODUCTION—"A SACRED TRUST"

*A great gift has been made to each and every one of us—the privilege of living in the world for a short span of years and the opportunity of doing our part to help the less fortunate; to improve civilization; to advance knowledge, both the scientific knowledge of men and the "wisdom which is from above."*

—George Pepperdine, 1937

Pepperdine University is called to be a premier, global Christian university known for the integration of faith and scholarship in the service of humanity. Throughout its history, the University has been the recipient of innumerable blessings, including a preeminent location in Southern California, campuses on four continents, a new property in Washington, DC, exceptional faculty, talented staff, gifted students, loyal alumni, generous donors, and a compelling mission. Because we have freely received a rich heritage, we believe it is our mandate to give freely to others, and to share these intellectual, moral, and spiritual blessings with families, churches, communities, the nation, and the world. Pepperdine University enjoys a distinctive ethos, mission, and character that will equip and empower it to serve the needs of our society and the world. With our founder, Mr. Pepperdine, we firmly believe that we have been given a "sacred trust" to which we must be faithful. Now is the time to rise to the occasion—to become a truly global university, earnest about scholarly inquiry and devoted to student learning, while remaining true to the founder's spiritual vision.

Since its founding in 1937, Pepperdine has continued to grow in its scholarly achievements and scope of service. From its modest beginnings as a Christian liberal arts college in central Los Angeles, the institution has blossomed into a distinguished university with a broad range of programs and a

diverse population of students, faculty, and staff. Today the University enjoys a singular reputation for excellence, both nationally and internationally. Students from more than 50 countries and virtually all the states study at the University's multiple campuses in the U.S., Europe, South America, and Asia. All the while, the institution has remained committed to its original calling, as expressed in the mission statement:

*Pepperdine is a Christian university committed to the highest standards of academic excellence and Christian values, where students are strengthened for lives of purpose, service, and leadership.*

Our core commitments inspire us, direct us, and determine our relentless striving for excellence. As a Christian university, Pepperdine affirms:

- That God is
- That God is revealed uniquely in Christ
- That the educational process may not, with impunity, be divorced from the divine process
- That the student, as a person of infinite dignity, is the heart of the educational enterprise
- That the quality of student life is a valid concern of the University
- That truth, having nothing to fear from investigation, should be pursued relentlessly in every discipline
- That spiritual commitment, tolerating no excuse for mediocrity, demands the highest standards of academic excellence
- That freedom, whether spiritual, intellectual, or economic, is indivisible
- That knowledge calls, ultimately, for a life of service.

Distinctive institutional values and practices derive from these core commitments, permeating the undergraduate and graduate curricula and the daily lives of students, faculty, and staff:

- The essential compatibility of the claims of scholarship and the call to discipleship
- The centrality of student learning
- A respect for the value of scholarly debate, honest inquiry, and the passionate search for truth
- A focus on ethics and honorable conduct at all times
- A global perspective on learning, service, and civic obligation
- A hospitable welcome that affirms the worth of the individual and the dignity of persons
- A commitment to spiritual and intellectual formation
- A respect for and proper care of Creation

Though much has been accomplished in the last seven decades, there is a growing sense that Pepperdine University has only begun the momentous journey to which it has been called. In the years to come, we must imagine new possibilities—new programs, new opportunities, and new structural configurations. In the words of President Andrew Benton, "our horizons are boundless."



---

## VISION STATEMENT

*Pepperdine University will be a preeminent, global, Christian university, known for the integration of faith and learning, whose graduates lead purposeful lives as servant-minded leaders throughout the world.*

Our vision statement declares what we intend to become. George Pepperdine envisioned an institution that would transform students' lives so that they would, in turn, impact culture. He imagined a vast body of alumni—men and women conscious of their good fortune, recipients of the generous gift of a Christian education—who would feel the moral imperative to serve others sacrificially. Hence, the school's motto: "*Freely ye received, freely give*" (Matthew 10:8).

---

## STRATEGIC GOALS

While the mission and vision remain constant, the means to fulfill these aspirations may change over time. The goals that will guide the University in the next decade were succinctly articulated by President Andrew K. Benton in his 2010 address entitled "Boundless Horizons." In that message the president outlined five major themes in the University's future: (1) advancing learning, knowledge, and scholarship; (2) developing resources; (3) building community; (4) respecting diversity and promoting global understanding; and (5) honoring God and heritage. Guided by—and building upon—these five central themes, the University community commits itself to five strategic goals articulated in this strategic plan.

In order to determine our progress, these strategic goals will be measured periodically at the university and unit levels (i.e., by school, division,

department, and program). The schools and other units of the University will, over time, develop individual strategic plans that support and harmonize with the University Strategic Plan. Every member of the University community is invited to participate in ongoing conversations about the University's goals and to help establish numerous specific short-term and long-term initiatives. The intention, then, is to align the efforts at the school and operational levels as closely as possible with these strategic goals and to measure our progress, employing key performance indicators, at every step.

---

### GOAL 1—ADVANCE STUDENT LEARNING AND SUPERIOR SCHOLARSHIP.

We are committed to delivering an exceptional educational experience, for there can be no great university where there is no great learning. This goal includes the transmission of the wisdom of the past, as well as the discovery of new knowledge in our day, and the application of that wisdom and knowledge to a world in need. In short, Pepperdine will produce graduates able to meet the challenges of the 21<sup>st</sup> century. This educational experience will be exemplary, if we:

1. Attract and support educators devoted to student learning, who are recognized leaders in their disciplines and accomplished scholars committed to their own research and that of their students. We will recruit and support scholar-teachers who are capable of going beyond disciplinary boundaries in order to increase the understanding of a complex world and who employ effective pedagogies that result in measurable achievement.

2. Attract and support excellent students committed to learning and inspired by our mission.
3. Continue to build a community devoted to strong ethical behavior, ensuring that this value is embedded in the curriculum, the cocurriculum, and all institutional practices.
4. Continue to invest in the University libraries, building collections and improving facilities to ensure that our libraries excel at providing superior resources and offering inviting spaces for collaborative learning.
5. Continue to support an entrepreneurial spirit. Our founder and our benefactors have been entrepreneurs in inclination and in practice. Given the world's hunger for sustainable solutions, Pepperdine must inspire others to lead through discovering new ways of understanding and serving society and the world.

---

### GOAL 2—STRENGTHEN OUR COMMITMENT TO THE FAITH MISSION OF THE UNIVERSITY.

Mr. Pepperdine founded the University because he believed that as recipients of God's favor, we must employ our talents in his service. He said, "*This gift of human life and the opportunity which is ours to serve others for a short time should be regarded as a sacred trust.*" As a Christian institution of higher learning, we honor the great traditions of scholarship, research, service, and worship whose roots reach back to the foundations of the first European universities, which were Christian in origin and mission. Through the ages, *believing* and *thinking* have been considered two dimensions

to a single enterprise. Historically, learning and the love of God and neighbor have been seen as complementary portals leading to knowledge of the creation and the Creator. In the Christian university, then, faith, hope, and love are not seen as impediments to discovery but as complementary to it. In the years ahead the University will:

1. Strengthen its ties to Churches of Christ by reaffirming the University's relationship to the Church, by renewing the commitment to recruit students from Churches of Christ and other Christian communions, and by hiring and mentoring staff and faculty from Churches of Christ and other Christian fellowships.
2. Enhance the University's outreach to churches through a review of the design of the annual Bible Lectures and the Office of Church Relations.
3. Strengthen the various parts of the University concerned with spiritual formation, including the Center for Faith and Learning, the University chaplaincy, campus ministries, the Religion Division, the Office of Student Affairs, the Veritas Forum, graduate student fellowships, and so forth; and encourage greater cooperation among these units.
4. Support and encourage an integrative scholarship that inspires discipleship, and a kind of discipleship that leads to rigorous scholarship.

---

**GOAL 3—BUILD MEANINGFUL COMMUNITY AND ENDURING ALUMNI LOYALTY.**

Pepperdine’s faculty, staff, and students will be known for the quality of their life together, a life defined by honesty, integrity, civility, and compassion. The calling to love and care for others will inspire members of the community to practice hospitality to a profound degree. This kind of learning environment educates the whole person and inspires lifelong devotion to and deep pride in Alma Mater. In order to fulfill Mr. Pepperdine’s mandate “*to continue the widening waves of good citizenship and Christian influence,*” we must:

1. Increase alumni ownership of the Pepperdine vision through involvement in service, connecting graduates with alumni chapters and increasing opportunities for alumni to meet, mentor, and serve current students and fellow alumni.
2. Increase the quality of dialogue and sense of community among faculty, staff, students, alumni, and administration.
3. Offer excellent career development opportunities that will increase alumni connections to and appreciation for Alma Mater.
4. Foster lasting friendships and institutional loyalty through exceptional classroom experiences, collaborative research opportunities, and enriched cocurricular opportunities.
5. Improve residential life through the new Campus Life Project that will include the construction of a new residence hall for juniors.
6. Increase the prominence of athletic programs, construct a new events center, and build a new

student recreation facility—with the aims to develop character, provide enjoyment, and inspire lasting memories and alumni loyalty.

7. Increase the prominence of the arts, including performing, visual, and media arts programs, to foster the spirit of creativity and ingenuity among Pepperdine students, artists, alumni, and participants throughout the Greater Los Angeles area.

---

**GOAL 4—INCREASE INSTITUTIONAL DIVERSITY CONSISTENT WITH OUR MISSION.**

Pepperdine University resides in a culturally diverse metropolis on the Pacific Rim, with study abroad opportunities in many locations, enjoying affiliations with major universities around the globe. Just as the first universities were transnational enterprises, so Pepperdine University intends to be a contemporary expression of such a global, intellectual community. Furthermore, the Gospel calls us to love justice and to treat every person with respect and compassion, to affirm in humility that we are finite beings and therefore limited in knowledge. It is through the inclusion and experience of others from diverse backgrounds and points of view that we are able to see dimensions of truth otherwise unavailable us. Given our geography, our history, and our commitment to the Gospel, we believe that diversity does not simply enrich the educational endeavor; it is central to it. Therefore, because we seek to be—and to be known as—a welcoming community serving local, national, and international communities, we must:

1. Advance the diversity of the student body, faculty, and staff. This includes increasing access

and enhancing the quality of the campus climate, providing welcoming spaces and opportunities for building meaningful community.

2. Educate students for service in diverse settings, whether in local or distant communities, and encourage all students to participate in a multicultural and/or international study experience, instilling the conviction that they must be fully engaged citizens of local communities, as well as responsible members of national and international communities.
3. Welcome international students, integrating them into our campus communities, drawing on their unique experiences and talents, and ensuring their contributions to the rich tapestry of Pepperdine’s culture.
4. Provide spiritual, intellectual, and material support for students, faculty, and staff who study or serve abroad.
5. Model service and leadership within local communities, congregations, and underserved populations.
6. Maintain our leadership as one of the most successful institutions in the U.S. in terms of the number of students who enjoy a study abroad experience.

---

**GOAL 5—DEVELOP RESOURCES THAT SUPPORT THE ASPIRATION TO BE A PREMIER, GLOBAL CHRISTIAN UNIVERSITY.**

A great vision cannot succeed without the support of talented and committed people and significant financial support to sustain it. If the

University is to attain its lofty goals, it follows that it must acquire the human and material resources to give substance to the dream. We must:

1. Recruit and retain talented students who love the mission of Pepperdine.
2. Hire, retain, and mentor talented employees who share a love for Pepperdine, its students, and its mission.
3. Increase the financial aid available to students and expand loan forgiveness programs.
4. Successfully complete the “Campaign for Pepperdine,” which will provide the financial, human, and social capital essential for success.
5. Ensure that each school’s enrollment is maintained at sustainable levels, thereby assuring both the academic quality of students and the tuition revenues necessary to the fiscal well-being of the schools and the University.
6. Improve the institution’s facilities to match our aspirations. We must build, renovate, and maintain aesthetic, functional, efficient facilities worthy of a preeminent institution of higher education. This includes remodeling regional campus facilities and selected international facilities.
7. Effectively steward existing financial, capital, and human resources in ways that support and sustain the University’s aspirations. Increase the endowment to place it among the top 50 university endowments in the U.S.

## CONCLUSION

*“I know the plans I have for you, says the Lord . . . to give you a future and a hope.” —Jeremiah 29:11*

It has often been said that Pepperdine University’s future is as bright as the promises of God. Secular universities today build for “the present age.” “Secular,” from the Latin *saeculum*, originally meant “the spirit of the age,” the “present times,” or “this generation.” It is a good thing to build something for the present age—for this generation. Indeed, like other leading universities, Pepperdine seeks to do just this; but we also are *building for eternity*.

In the 1930s George Pepperdine imagined a future Los Angeles as a great urban center that would influence all the regions of the globe. His vision has proven true. He had a similar dream for a great Christian institution of higher learning that would serve the world from this cosmopolitan crossroads. It is time to give greater expression to Mr. Pepperdine’s vision for Pepperdine. Through new opportunities, by God’s grace, we will more fully realize our calling to be a major global Christian university.

Through robust inquiry and service, informed by Christian conviction, we will honor God through the development of the mind, body, and spirit of the people of this generation, as well as of generations yet unborn. For this reason, our calling is great, our opportunities are immense, and our horizons are boundless.

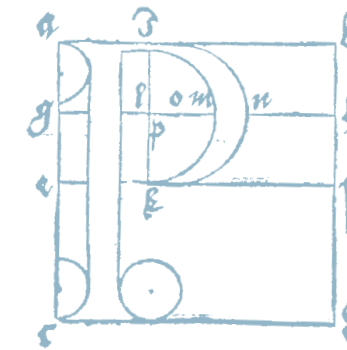

PEPPERDINE UNIVERSITY